

FabLite Hybrid Extrusion Kit FL-HE-2020-02

FL-HE-2020-02

FabLite Hybrid Extrusion exhibits and counters are a perfect solution for the serious exhibitor. Exhibits feature heavy-duty aluminum extrusion frames and push-fit fabric graphics. Count on making an unforgeable impact with FabLite Hybrid exhibit kits, counters, and accessories.



features and benefits:

- 11'10" tall square shaped island display
- Silver aluminum extrusion frame
- 16 single sided push-fit fabric graphics
- White laminate panel counter
- 16 Lumina 200 LED floodlights
- 8 Literature holders attach to extrusion
- Kit includes: one frame, sixteen fabric graphic panels, one white laminate counter, eight literature holders, sixteen lights, and one woodcrate
- Reception counter and flooring not included
- Lifetime hardware warranty against manufacturer defects

dimensions:

Hardware

Assembled unit:
153.5" w x 141.75" h x 153.5" d
3899mm(w) x 3601mm(h) x 3899mm(d)

Approximate weight:
703 lbs / 319 kg

Shipping

Packing case(s):
1 WOODCRATE-H

Shipping dimensions:
WOODCRATE:
101" l x 53" h x 49" d
2565mm(l) x 1346mm(h) x 1245mm(d)

Approximate total shipping weight:
1083 lbs / 492 kg

additional information:

Graphic material:
Dye-sublimation SEG push-fit fabric

Table holds max weight:
50 lbs / 23 kg

*Front reception counter, RCK-06, not included.

Panel Colors:



3 person assembly recommended:



This product may include the following materials for recycle:
aluminum, select wood, fabric, cardboard, paper, steel, and plastics.

Included In Your Kit

Tools, Components, & Connectors



HEX KEY SET x1



PM4S2-1200-A315-A315 x8



PM4S2-2400-A315-A315 x8



PM4S2-1200-L-L x8



PM4S2-2400-L-L x8



PM4U-1200-L-L x4



PM4U-2400-L-L x4



FC-1086 x16



FC-1200-ROUTES x16



FC-2186 x16



FC-2400-ROUTES x16



PL-600-900 x2



PL-1200-900 x1



PL-CD-1200-900 x1



L90S-900 x4

Included In Your Kit

Components & Connectors



HP-CT-3 x1

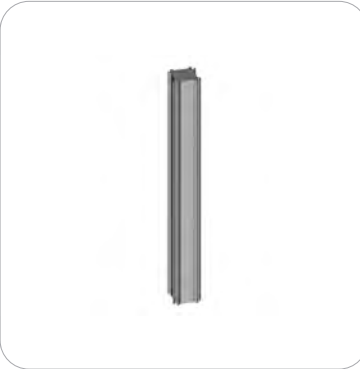

PM4DSC-600 x8



LN112 x8



LUM-LED2-ORL-S x16

Graphics

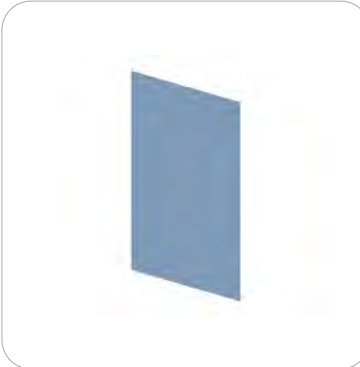

HP-18-A1-G x1



HP-18-A2-G x1



HP-18-B1-G x1



HP-18-B2-G x1



HP-18-C1-G x1

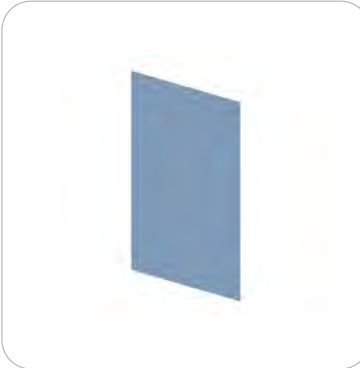

HP-18-C2-G x1



HP-18-D1-G x1



HP-18-D2-G x1



HP-18-E1-G x1



HP-18-E2-G x1

Included In Your Kit

Graphics

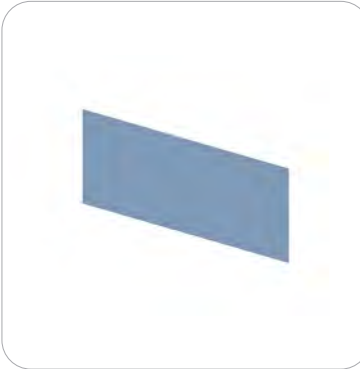

HP-18-F1-G x1



HP-18-F2-G x1



HP-18-G1-G x1



HP-18-G2-G x1



HP-18-H1-G x1

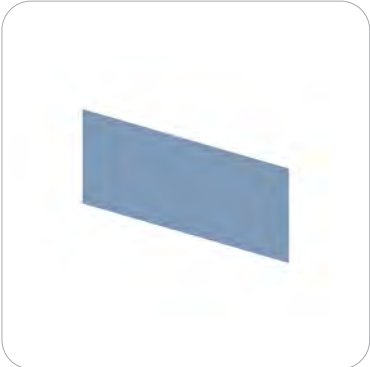

HP-18-H2-G x1

Exploded View

FL-HE-2020-02
View 1

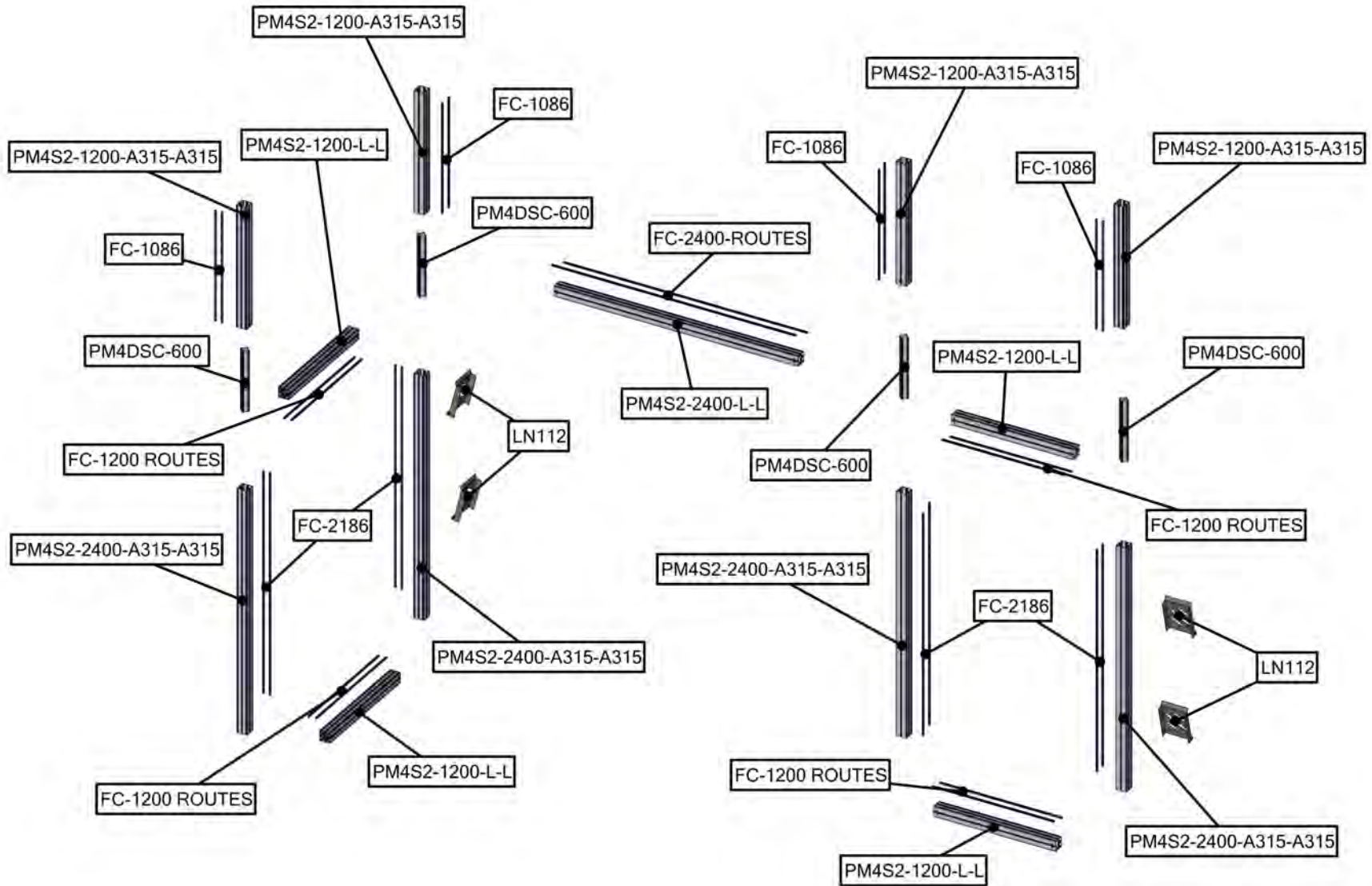

Exploded View

FL-HE-2020-02
View 2

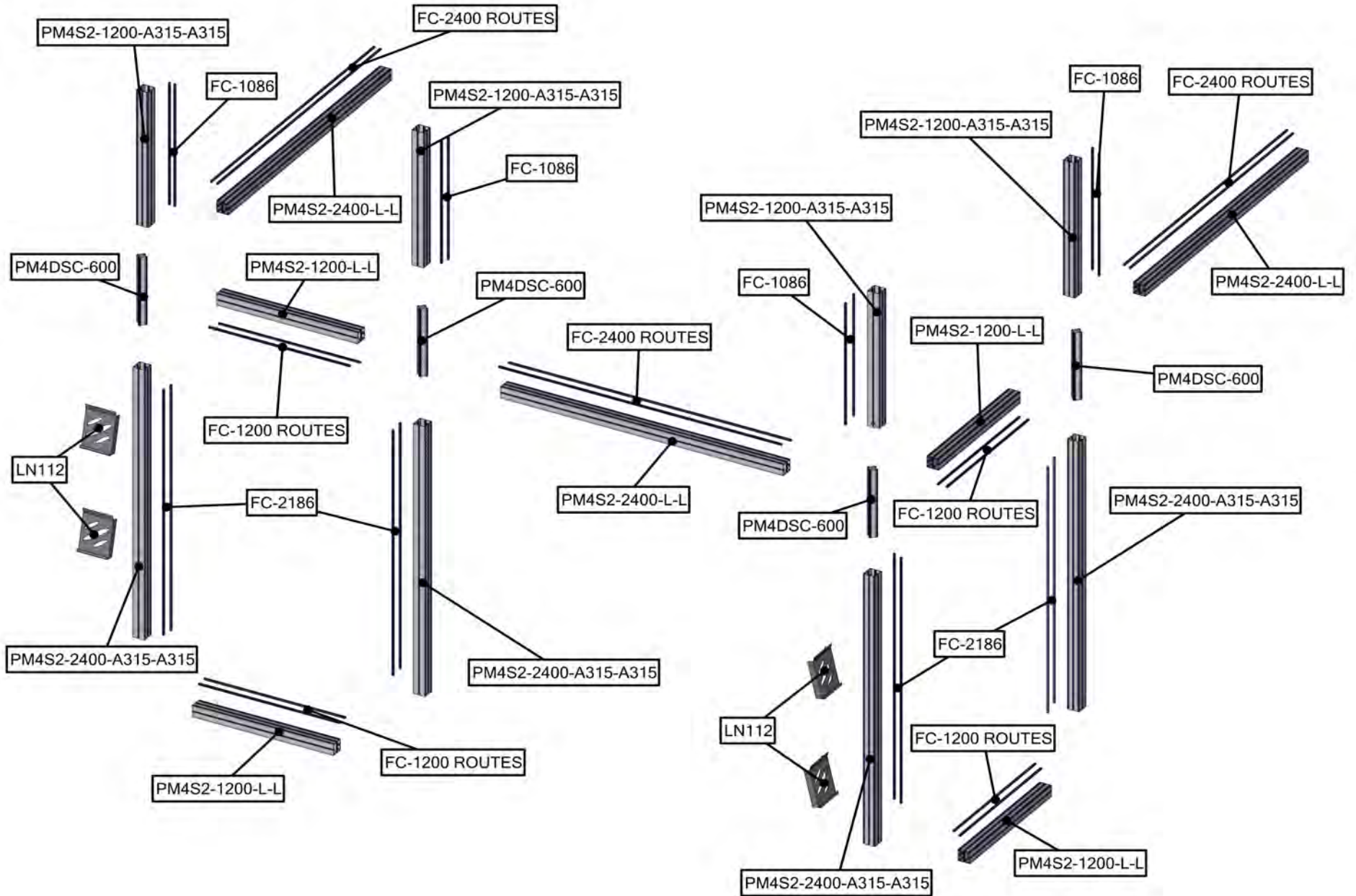

Exploded View

FL-HE-2020-02
View 3

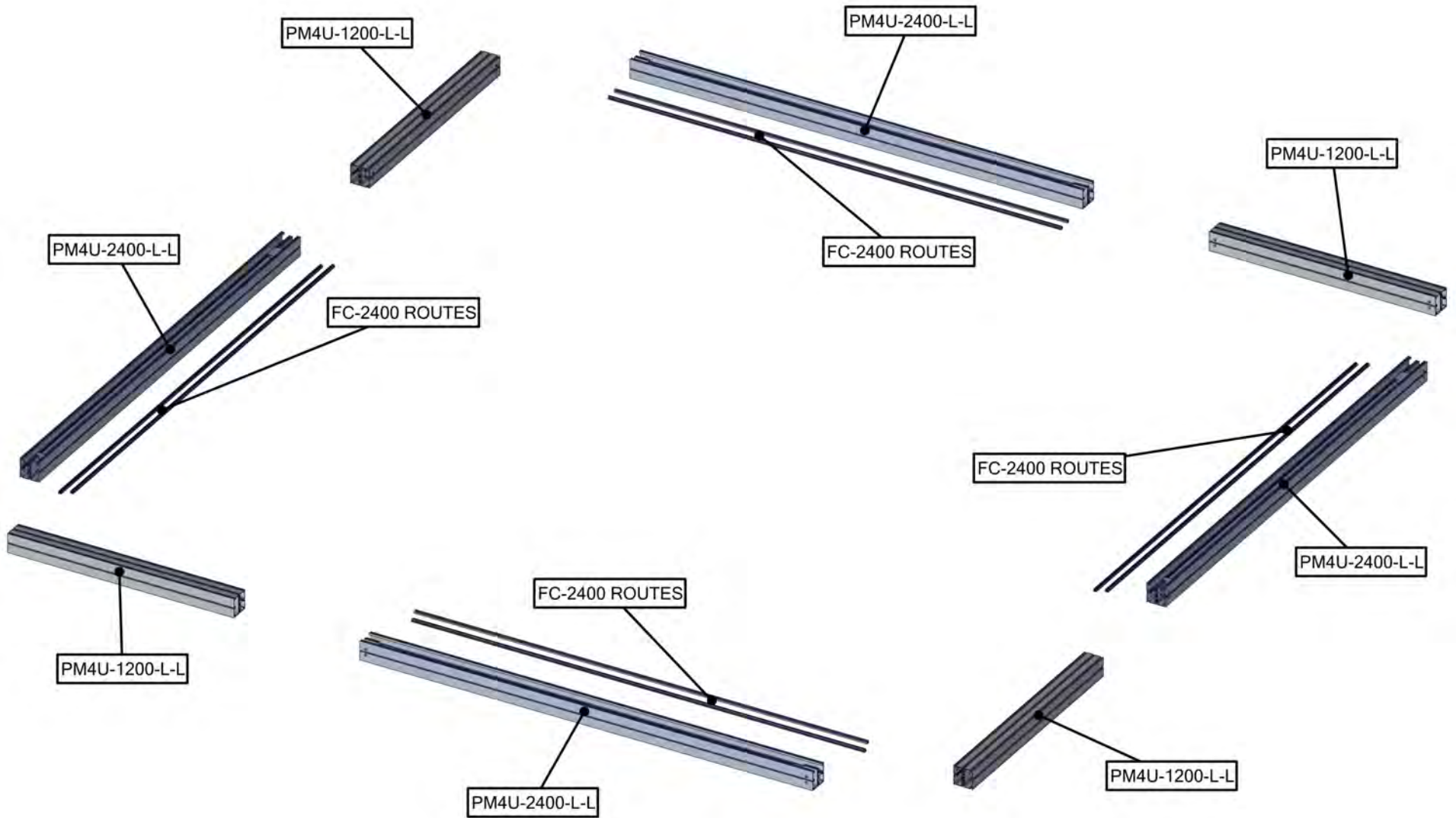

Exploded View

FL-HE-2020-02
Counter View

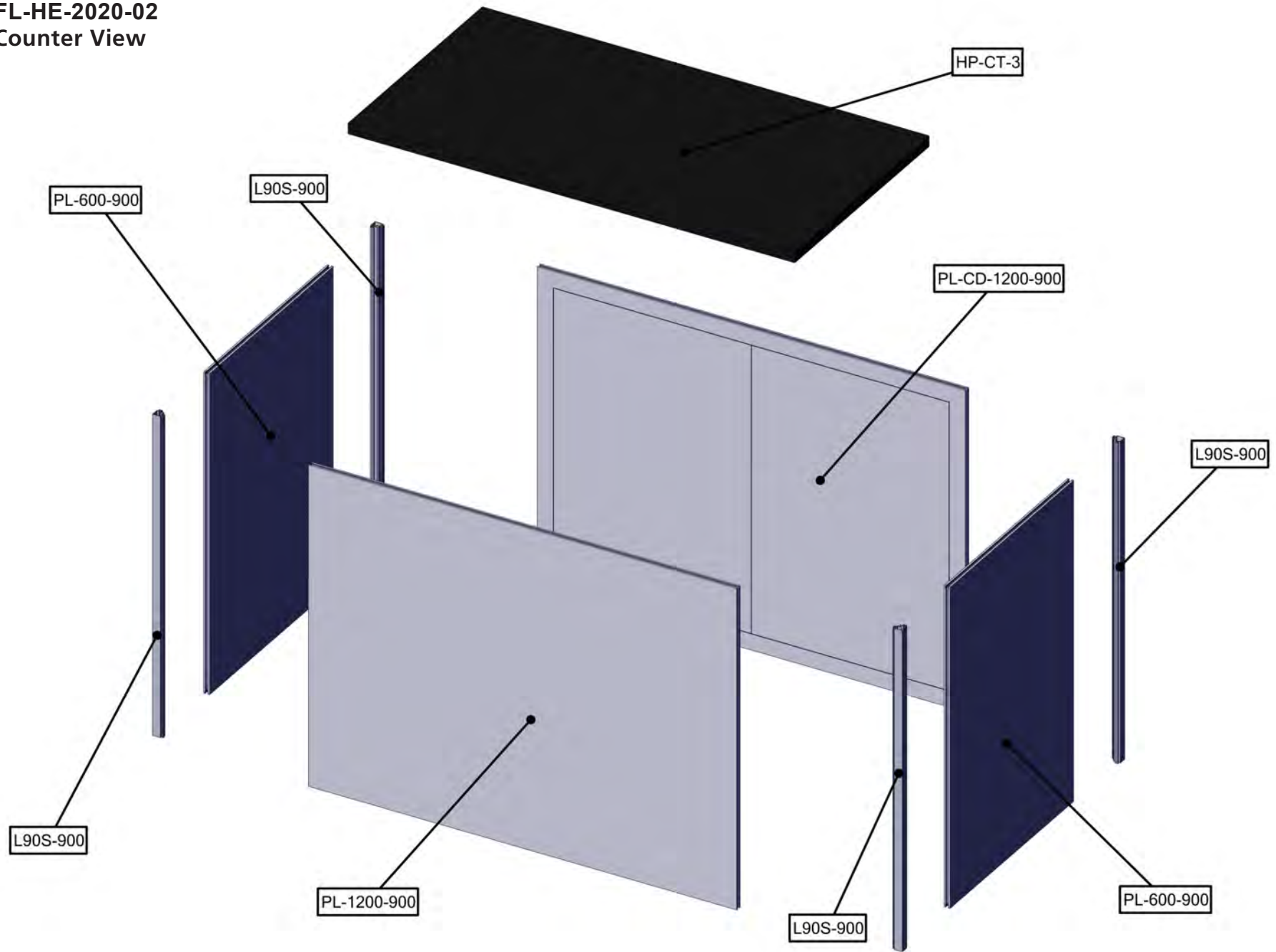

Kit Assembly

Step by Step

Step 1.

Gather the components to build the bottom section of the back of the frame. Use the Exploded View for part labels.

Reference Connection Methods 1, 2, 3, and 5 for more details.



Step 2.

Gather the components to build the middle section of the back of the frame. Use the Exploded View for part labels.

Reference Connection Methods 1, 3, 5, and 7 for more details.

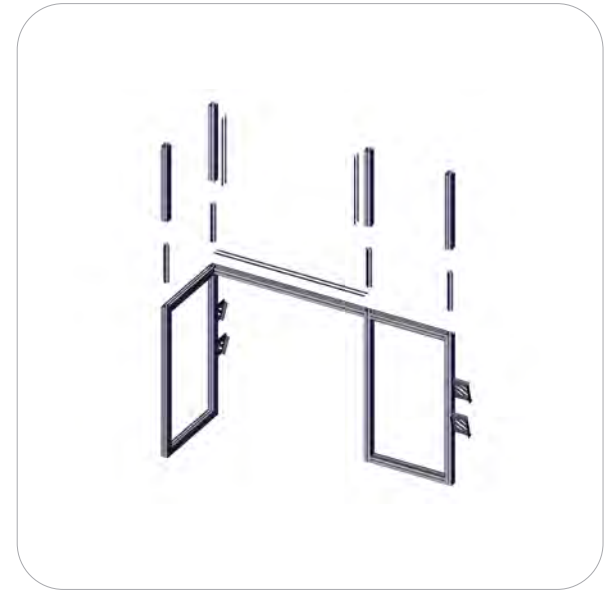

Step 3.

Build the first part of the front of the frame and connect it to the back using the extrusions. Slide the (2) LN112s onto the front extrusion before attaching the second extrusion on top of it.

Reference Connection Methods 1, 2, 3, 5, and 7 for more details.



Step 4.

Gather the components to build the rest of the bottom of the front of the frame. Use the Exploded View for part labels.

Reference Connection Methods 1, 2, 3, and 5 for more details.

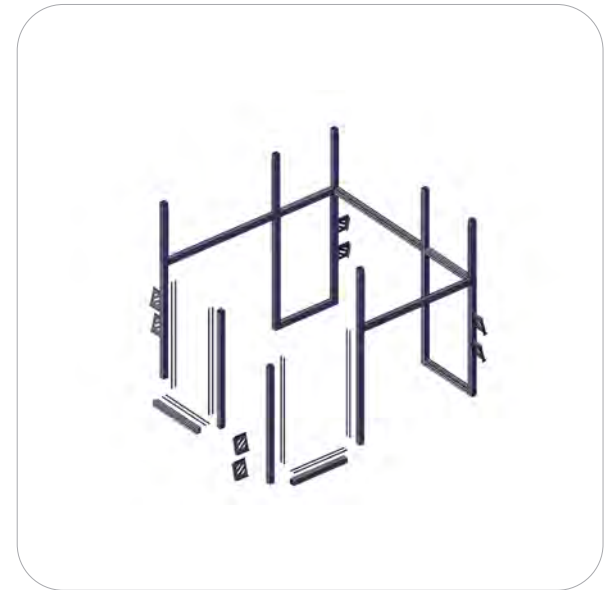

Kit Assembly

Step by Step

Step 5.

Gather the components to build the middle section of the front of the frame. Use the Exploded View for part labels.

Reference Connection Methods 1, 3, and 5 for more details.



Step 6.

Finish building the frame by attaching the top section to the rest of the frame. Use the Exploded View for part labels.

Reference Connection Methods 1, 3, and 5 for more details.



Step 7.

Attach the lower graphics to the frame.

Reference Connection Method 5 for more details.

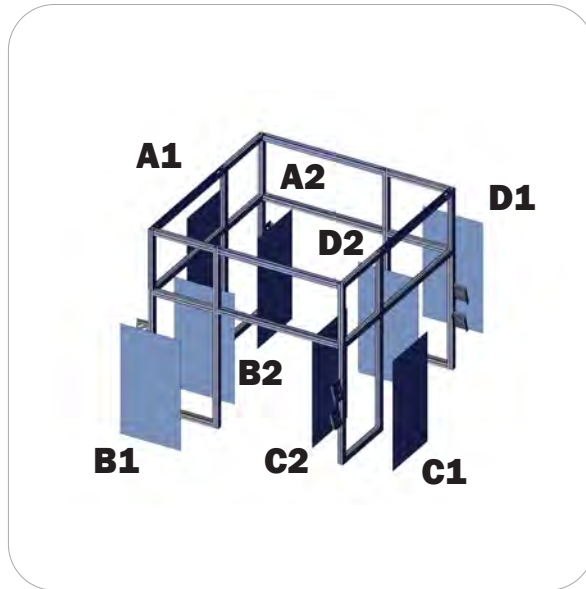

Step 8.

Build the counter and put it in its respective position.

Reference Connection Method 4 for more details.



Kit Assembly

Step by Step

Step 9.

Attach the upper graphics to the frame.

Reference Connection Method 5 for more details.

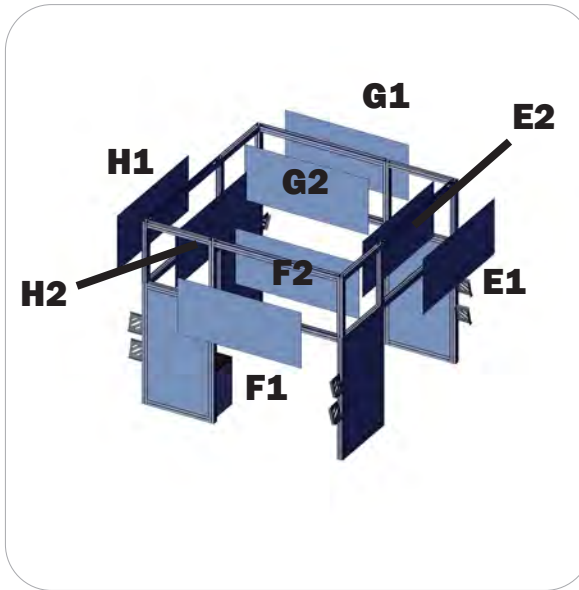

Step 10.

Clip the lights onto the top of the frame.

Reference Connection Method 6 for more details.

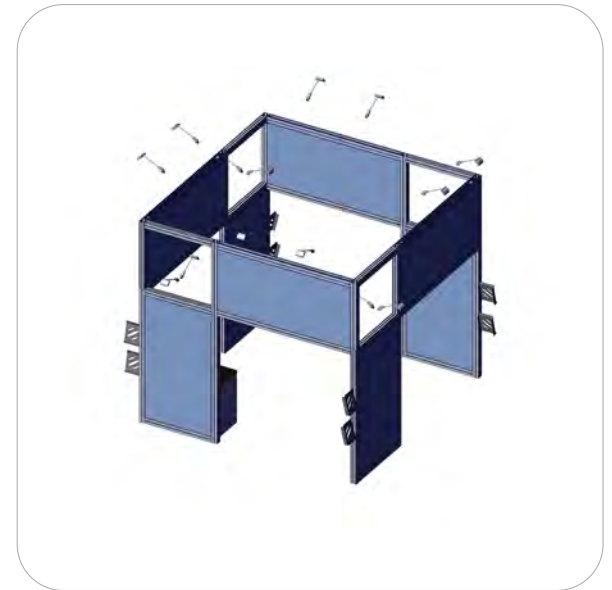

Connection Methods

Connection Method 1: PM4S2

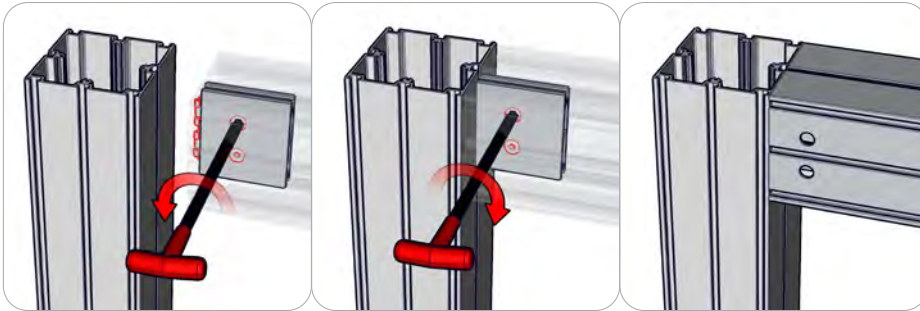

First, with the cam lock disengaged, place the cam lock teeth into the extrusion channel. Second, use the allen key tool to lock it in place. Make half turns clock-wise to engage the cam lock. Do not over tighten the lock buttons.

Connection Method 2: Literature Pockets LN112

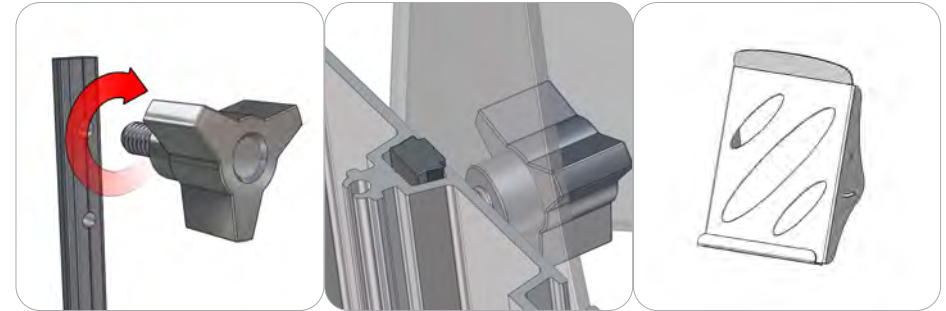

First, untighten the knobs. Second, slide the LN112 down the extrusion. Third, tighten the knobs to keep the LN112 in place.

Connection Method 3: PH-L / PH-S / PHFC2 / PHFC4



First, with the cam lock disengaged, place the cam lock teeth into the extrusion channel. Second, use the allen key tool to lock it in place. Make half turns clock-wise to engage the cam lock. Do not over tighten the lock buttons.

Connection Method 4: Link Profiles

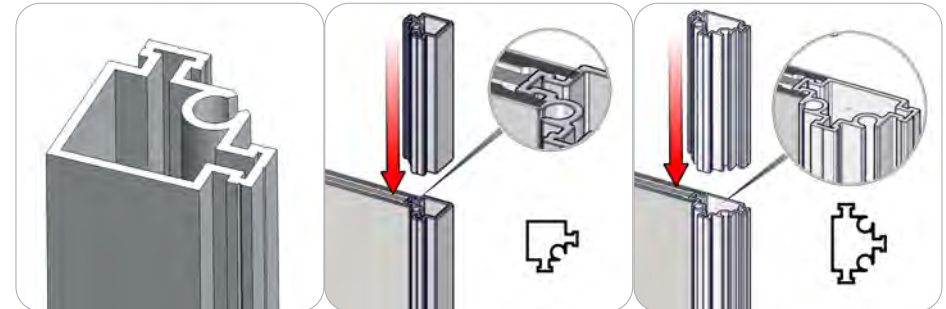

Take the link profile extrusion and slide it into the channel of the next component. There maybe tension glides in that channel, they will help hold the link in place. Make sure the link profile connection is flush at both ends.

Connection Methods

Connection Method 5: FC

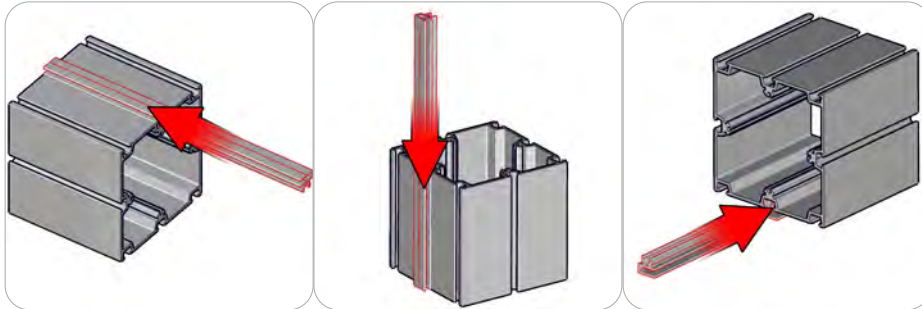

Take the Fabric Channel extrusion (FC) and align it with the desired channel of the next extrusion. Simply slide the FC extrusion into the channels of the extrusion. When making a frame with FC, make sure the channels are all facing in the same direction and are aligned from channel to channel. Slide the FC extrusions into the channels of the extrusion before attaching the extrusions together when making a frame.

Connection Method 6: Graphic Application

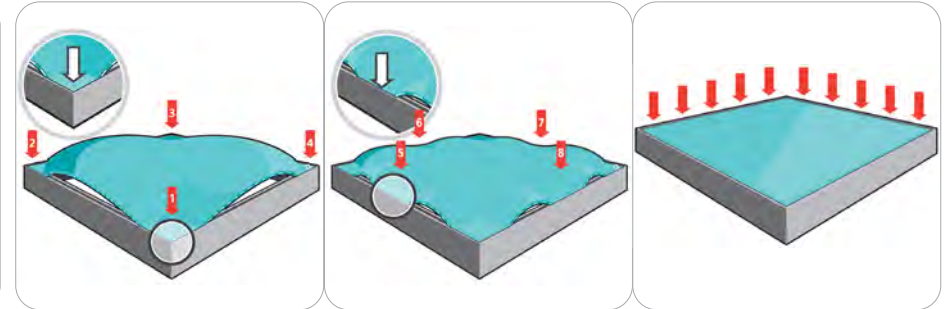

First, insert the silicone edge frame corners into the frame graphic channel (points 1 through 4). Second, insert the silicone edge frame sides into the frame graphic channel (points 5 through 8). Third, push the remaining silicone edge fabric into the frame graphic channel. Similar setup is recommended for the opaque liner. To remove these panels, simply pull the loop tag sewn near a corner.

Connection Method 7: PM4DSC

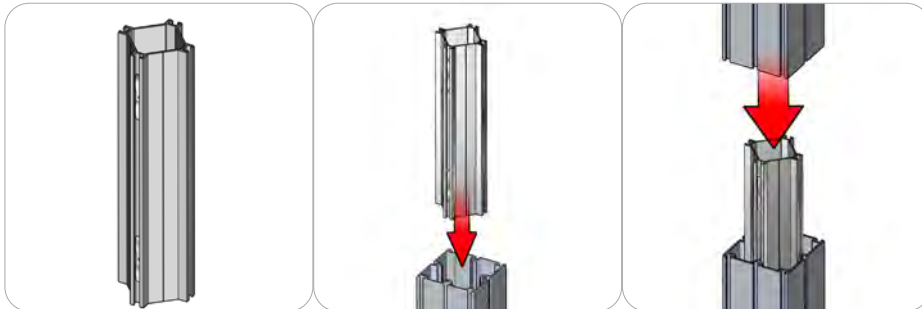

First, take the PM4DSC connector and align it with the internal channels of the next extrusion. Second, slide the connector into the inside channels of the extrusion. The tension glides on the connector will keep it center and snug. The extrusion will have stop pins pre installed to stop it from sinking in. Third, take the next extrusion and apply it on top of the connector completing your connection.

Connection Method 8: LUM-LED2-ORL-S

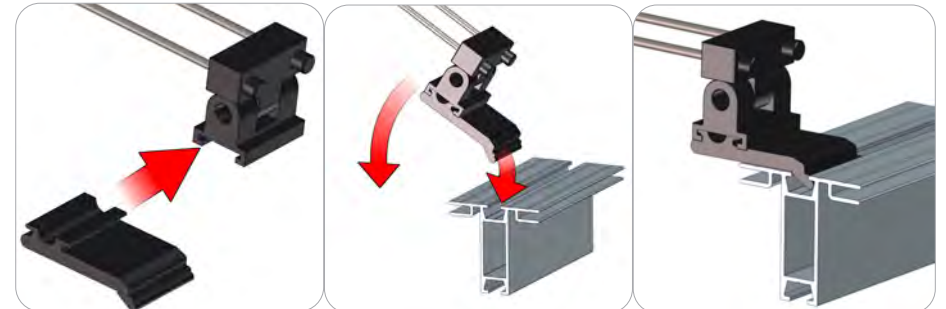

First, slide the light clip into the dove tail end of the spot light. Second, rest the light clip into the extrusion channel. Make adjustments to the spot light if necessary.