

FabLite Designer Series 30' Kit 04 - FL30-DS04

FL30-DS04

FabLite Designer Series 30ft displays have unique stylistic features and shapes, are portable and easy to assemble. The aluminum tube frame features snap-buttons and/or spigot connections and zipper pillowcase fabric graphics. All displays come in portable, wheeled transit cases. Simply pull the pillowcase fabric graphic(s) over the frame and zip.



features and benefits:

- Premium aluminum tube frames with snap button/ spigot assembly
- Vertical curved shaped frame
- Easy to store and ship
- Quick to set up
- Weighted feet for added stability
- Zipper pillowcase fabric graphic
- Lifetime limited hardware warranty against manufacturer defects

dimensions:

Hardware	Graphic
<p>Assembled unit: 350.05" w x 91.84" h x 23.97" d 8891 mm(w) x 2333 mm(h) x 609 mm(d)</p> <p>Approximate weight with cases: 118 lbs / 53.5 kgs</p>	<p>Refer to related graphic template for more information.</p> <p>Visit: www.exhibitors-handbook.com/graphic-templates</p>
<p>Shipping</p> <p>Packing case(s): 2 OCE</p> <p>Shipping dimensions: 41" l x 18" h x 17" d 1042 mm(l) x 458 mm(h) x 432 mm(d)</p> <p>Approximate total shipping weight (includes cases & graphics): 149 lbs / 67.6 kgs</p>	<p>additional information:</p> <p>Graphic material: dye-sublimation zipper pillowcase fabric</p>

We are continually improving and modifying our product range and reserve the right to vary the specifications without prior notice. All dimensions and weights quoted are approximate and we accept no responsibility for variance. E&OE. See Graphic Templates for graphic bleed specifications.

Included In Your Kit

Tools, Components,
& Connectors



ALLEN KEY SET x1



TC-30-90T x2



LN114-SCRW x2



PLT-BP-WVC-STD x2

Graphics



FMLT-DS-30-04-G x1

Included In Your Kit

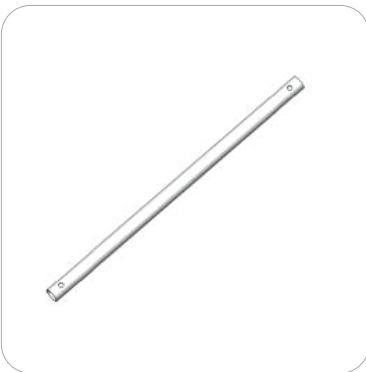

WV10-01-T1 x18



WV10-01-T2 x10



WV10-01-T4 x3



WV10-01-T5 x3



WV10-01-T6-PART C x2

Tubes



WV10-01-T7 x3



WV10-01-T7-V2 x2



WV10-01-T2-L x1



WV10-01-T2-R x1



WV20-01-T1 x2



WV20-01-T2 x2



WV20-01-T7 x2

Exploded View

FL30-DS04

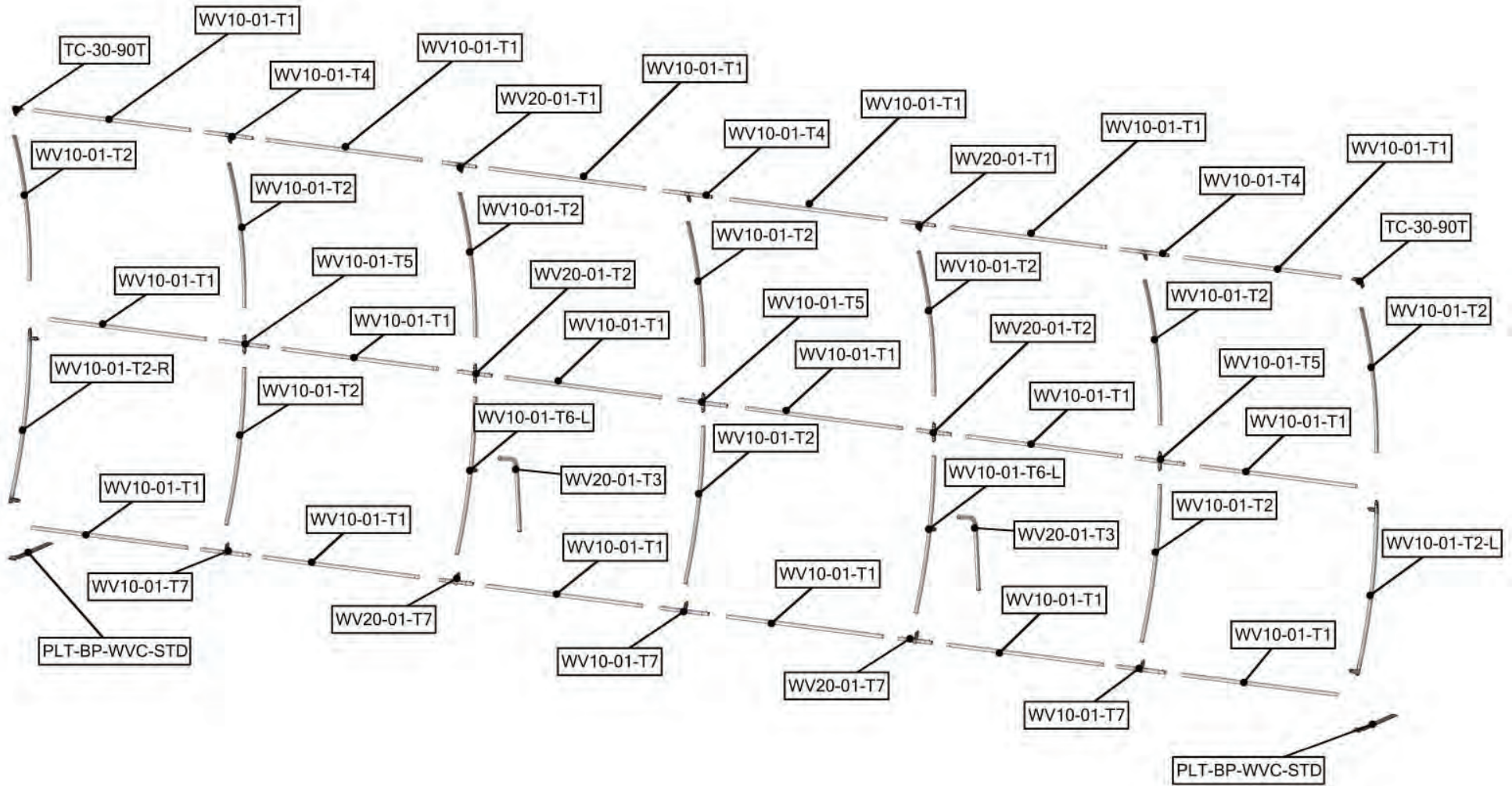

Labeling Diagram

FL30-DS04

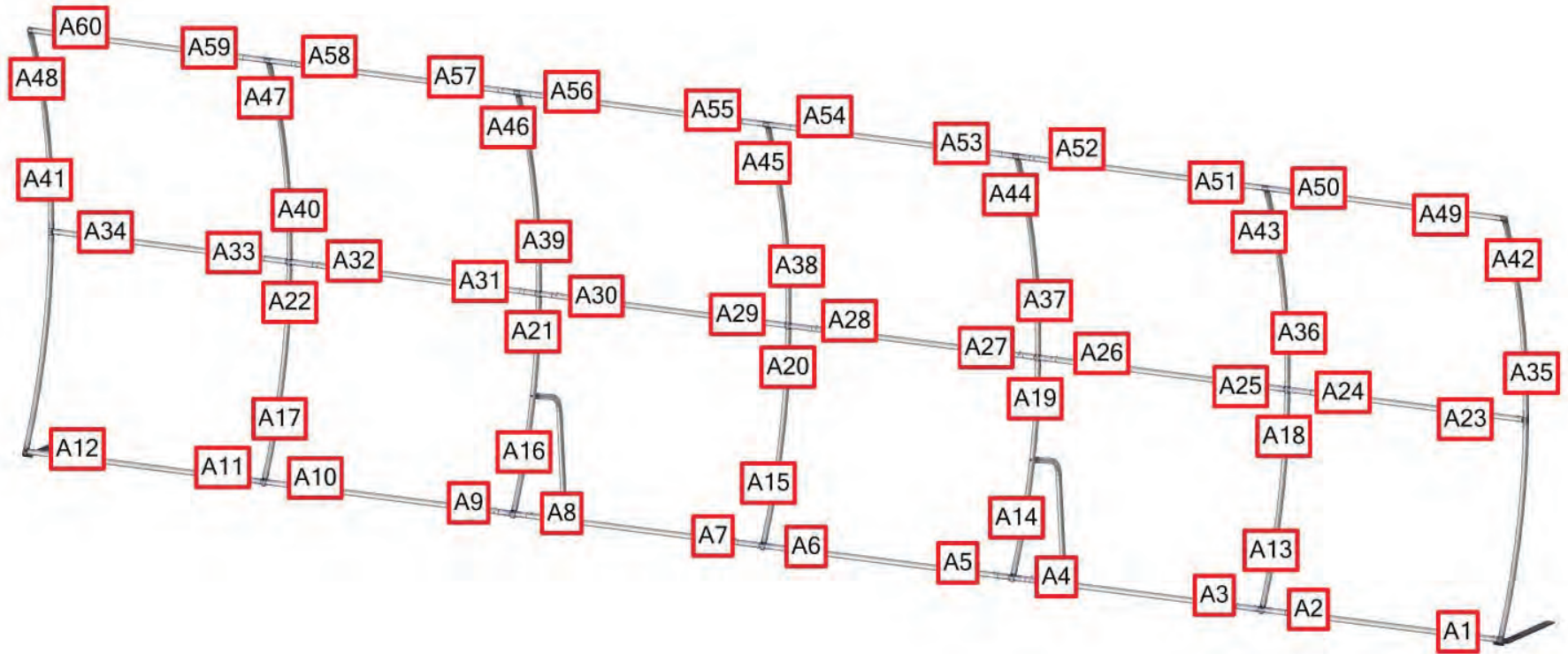

Kit Assembly

Step by Step

Step 1.

Assemble Frame A according to the Labeling Diagram.

Please reference Connection Method 1 for more details.

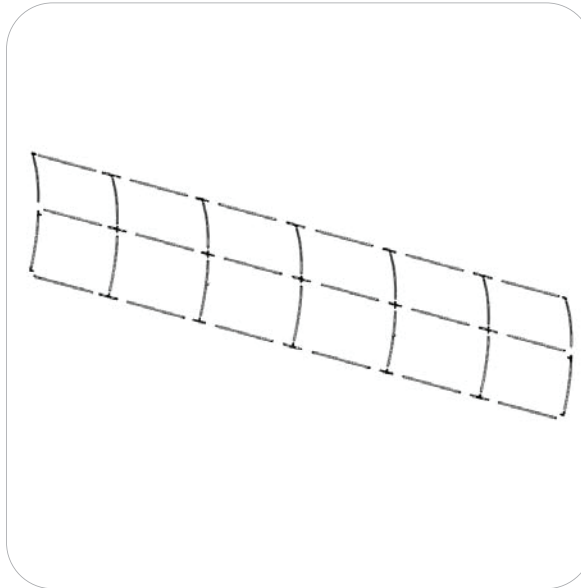
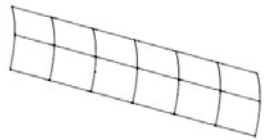

Step 2.

Apply FMLT-DS-30-04-G graphic to the frame by pulling the pillowcase over the top.

Zipper located to the bottom of the Graphic.

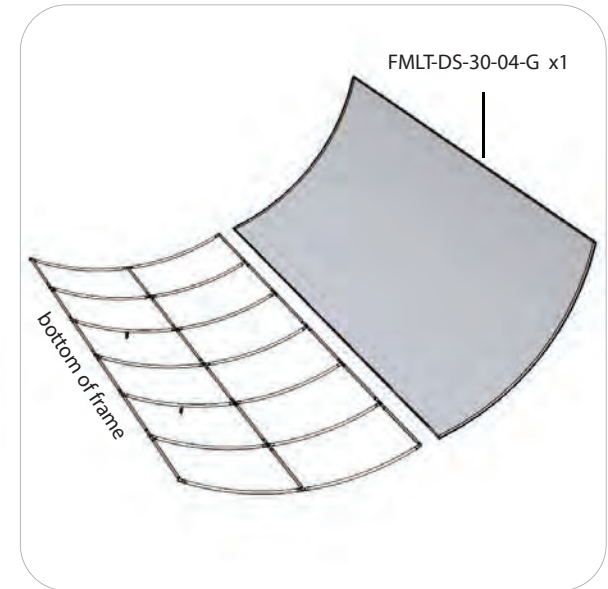

Step 7.

Attach the WV10-01-T7-V2 to the backsides of the middle sections D. This component attaches with the snap button feature.

Please reference Connection Method 1 for more details.

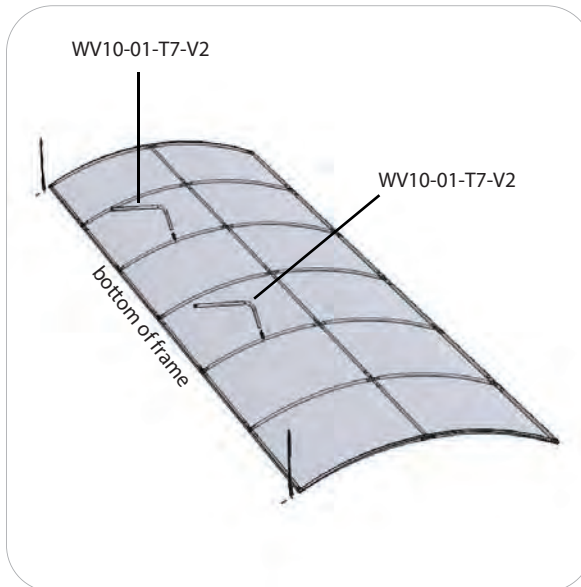

Step 8.

Attach the PLT-BP-WVC-STD to the outside ends of frame sections A and B. Use the provided handtool to securely fasten them onto the frame.

Setup Complete.

