

FabLite 10' Vertical Curve - FL10-VC

FL10-VC

FabLite is a collection of sophisticated, ergonomically designed exhibit booths. FabLite combines state-of-the-art zipper pillowcase dye-sublimated fabric coverings with advanced lightweight aluminum structures to provide unique design, functionality, and style. The excellence of the FabLite line of displays, hanging structures and products is simply unmatched. Stretch fabric graphics are hand-sewn, durable and dry-cleanable.



features and benefits:

- State-of-the-art 30mm aluminum tube frame with snap button assembly
- Easy to store and ship
- Quick to set up
- Kit includes: one frame, one dye-sublimated zipper pillowcase graphic, and one wheeled molded OCL storage case
- Lifetime hardware warranty against manufacturer defects

dimensions:

| Hardware | Graphic |
|--|---|
| <p>Assembled unit: 114"w x 92"h x 24"d 2896mm(w) x 2337mm(h) x 610mm(d)</p> <p>Approximate weight (includes graphic): 28.63 lbs / 13 kg</p> | <p>Total visual area: 114"w x 94.5"h 2896mm(w) x 2400mm(h)</p> <p>Please be sure to include a 2" bleed around the perimeter.</p> <p>Refer to related graphic template for more information.</p> |
| <p>Shipping</p> <p>Shipping dimensions: 1 OCL case: 19"l x 19"w x 56"h 483mm(l) x 483mm(w) x 1422mm(h)</p> <p>Approximate shipping weight (with case): 48.63 lbs / 22 kg</p> | |

additional information:

Graphic material:
Dye-sublimated zipper pillowcase fabric

Optional Accessories:
Lumina 8-50 watt halogen lighting, literature pocket, stand-off graphic shelf, graphic header, larger freight cases

| Parts Included | | |
|---|-----|---------------|
| Part Label | Qty | Part Code |
| FABRIC GRAPHIC | x1 | WV10-01-G |
| LN114 BOLT | x2 | LN114 BOLT |
| 90 DEGREE ELBOW JOINT FOR 30MM TUBING | x2 | TC-30-90 |
| 1270MM X 30MM TUBE | x6 | WV10-01-T1 |
| 30MM CURVED TUBE WITH PART T AND 90B LEFT SIDE | x1 | WV10-01-T2-L |
| 30MM CURVED TUBE WITH PART T AND 90B RIGHT SIDE | x1 | WV10-01-T2-R |
| R2250 (1163MM ARC) CURVED TUBE | x4 | WV10-01-T2 |
| (2) 128MM TUBES SWAGED WITH PART TC-30-T | x2 | WV10-01-T7 |
| (2) 128MM TUBES SWAGED WITH PART TC-30-X | x1 | WV10-01-T5 |
| STEEL PLATE FOR WVC | x2 | WVC-PLATE-STD |

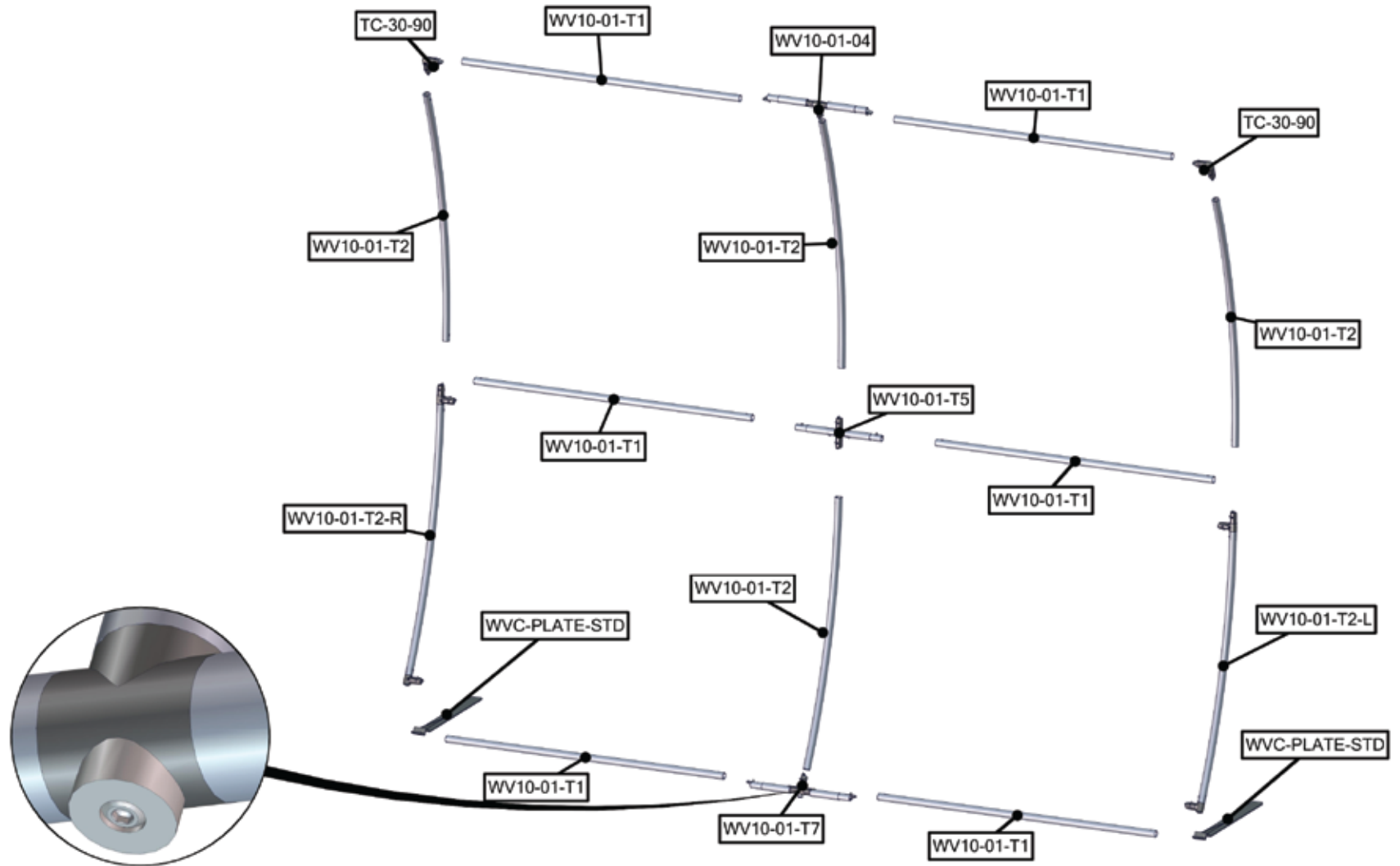

FabLite 10' Vertical Curve - FL10-VC

STEP 1: ASSEMBLE FRAME

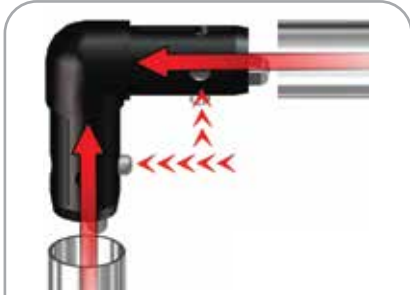

Assemble top frame corners using TC-30-90. Label codes will be on backside of tube. It is best to assemble frame laying flat.

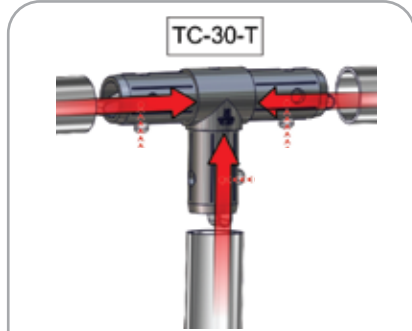

Connect sides of frame by lining up holes with snap buttons.



Use TC-30-90B to connect bottom frame corners; snap on button.

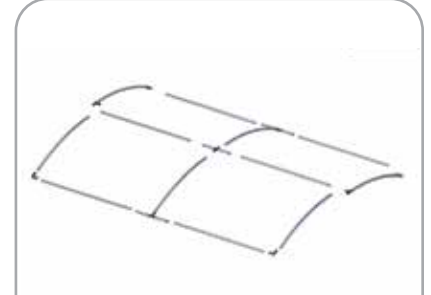

Frame assembly is complete once all sides and middle are connected.

STEP 2: ATTACH FEET

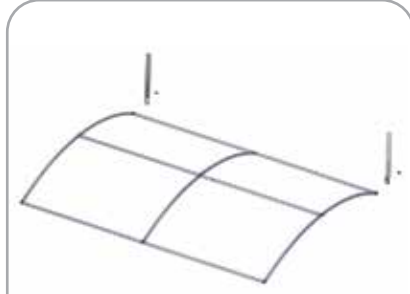

Attach feet with Allen key. See next step for detailed view.

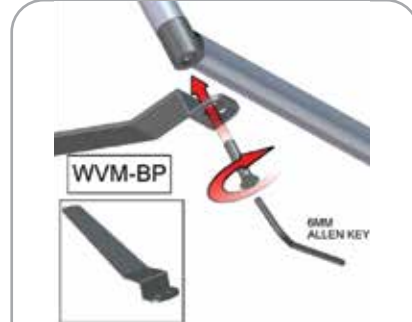

Using provided allen key, secure both feet (WVM-BP) to bottom of frame by tightening bolt.

STEP 3: ATTACH GRAPHIC

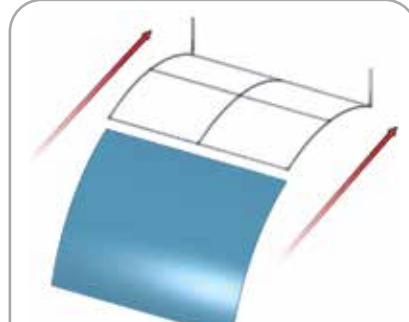

Slide graphic over top of frame.

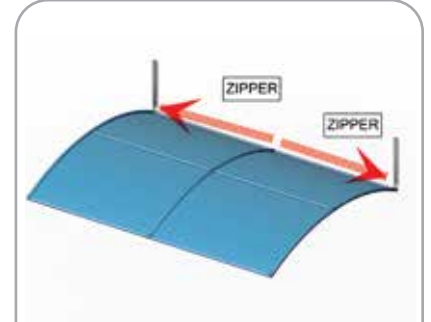

Zip fabric closed as shown along bottom.

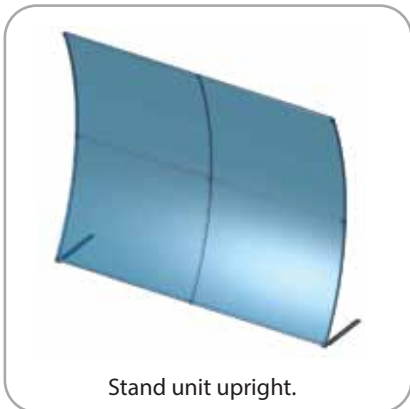

Stand unit upright.